

Rail King[®]

MOBILE RAILCAR MOVER

RK320 ^{G5}



Rail King Model RK320 G5 Mobile Railcar Mover provides up to 48,600 pounds of tractive effort.

Design Features

- Cummins QSB Tier IVi Engine
- Four Speed Automatic Transmission
- Royalglide operator comfort system
- Patented Cushion Coupler system
- Friction roadwheel drive
- Full width bumpers to protect powertrain
- Fabricated steel couplers
- Ergonomically designed full width cab layout
- Unsurpassed operator visibility
- Easy to use push button controls with color LCD display

Options

- Air conditioning
- Remote control
- Air-ride seats
- Central lube system
- Cold Weather protection package
- Step extensions
- Spotlights
- Turn signals
- Fire extinguisher
- 75-gallon (283 liters) fuel tank
- 100 CFM air compressor
- Other options available upon request

See Back For Product Specifications ▶ ▶ ▶ ▶

Rail King[®]
MOBILE RAILCAR MOVER

by

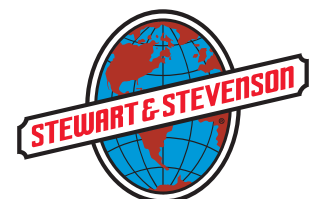

A Century of Innovation

Rail King Model RK320 G5

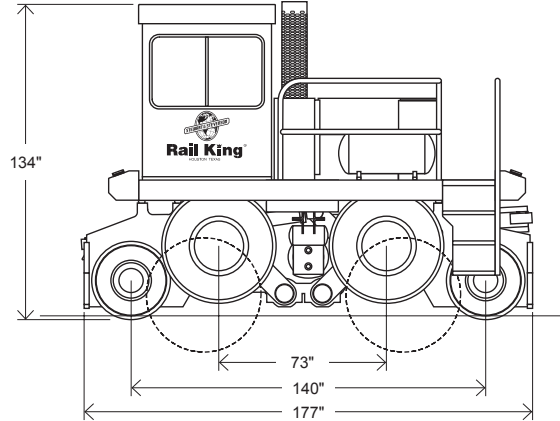
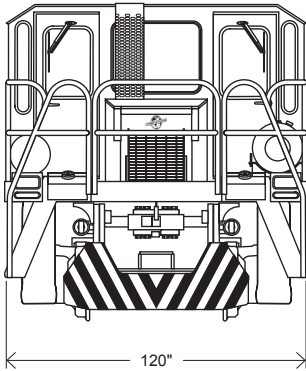

SPECIFICATIONS

GENERAL		
Weight	49,000 lb	22,2269 kg
Length	177"	449.6 cm
Width	120"	304.8 cm
Height (on road)	142"	360.7 cm
Height (on rail)	134"	340.4 cm
Rail Clearance	3"	76.2 mm
Road Clearance	10"	254 mm
Speeds (Forward & Reverse)	4	
On road	9 mi/h	14.4 km/h
On rail	15 mi/h	24.1 km/h

ENGINE	
Make	Cummins
Model	QSB 6.7
Type	Electronic, 4-cycle, turbocharged and charge air cooled
Fuel	Ultra Low Sulfur Diesel
Rated Power	194 bhp (145 kw) @ 2,000 rpm
Fuel Tank	40 gal (151 liters)
Features	US EPA Tier IVi/ (EU Stage IIIB) compliant

MAXIMUM TRACTIVE EFFORT	
When both couplers are used	48,600 lb
When one coupler is used	32,400 lb

Contact us today.

Stewart & Stevenson Rail King

Telephone: 713-671-6300
 www.railking.net
 email: railking@ssss.com
 8787 East Freeway
 Houston, TX 77029

Frame

Heavy-duty, welded from 2" steel plate

Engine

Cummins fully intergrated air-intake-to-exhaust aftertreatment low emission engine. Electronic management system provides better fuel economy, reduced particulate matter and lower NOx emissions. Utilizes Ultra Low Sulfur Diesel fuel.

Transmission

John Deere/ Funk DF150 with torque converter, four speeds forward and reverse; auto-shift or powershift speed selection , operator controlled start in second feature.

Rail- & Road-Drive

John Deere spiral bevel gear set; designed for bi-directional operation, no spin differential with internal planetary axles. Friction road wheel drive transmitted from rail axle incorporates separate braking system. Does not require special tires. Rail shock absorption system is standard.

Brakes

Rail wheel axle: Inboard multiple wet-disk brakes. Protected from contaminants and can last up to four times longer than dry-disk brakes. Spark-free for regulatory compliance in hazardous environments.
 Road wheel: heavy duty drum & shoe, hydraulic actuated
 Train Air Brakes: Push button operated to release or fully apply, modulating hand valve for controlled apply/release

Railwheels

28" diameter heat-treated cast steel. Bolt on, hardened flange with tapered tread contour.

Roadwheels

Heavy duty rock lug industrial tires.

Pneumatic System

High-capacity 50cfm air compressor system. Includes two compressors, three reservoirs with drains and air dryers.

Power Steering

Full hydrostatic power steering with improved turning radius.

Couplers

Two weight-transfer couplers made from fabricated steel (no castings). Couplers slide on high-density self-lubricating nylon bearings for long life and minimal maintenance. This heavy-duty coupler system operates on a center pivot housed in a massive synthetic rubber cushion pressed into both sides of the frame.

Sanders

Large capacity, replaceable steel sandboxes and eight air-operated sanding tubes with easy clean receivers: two for each rail wheel, front and back.

Full-width Cab

Provides excellent visibility down both sides of the railcar when negotiating curves. Standard equipment includes dual independent control stations, two fully adjustable seats, front and rear wipers, heater, ventilation fans, large opening side windows and tinted tempered safety glass, foot and hand throttle and brake actuators.

Controls

Improved console layout with full color LCD display, multicolor LED rocker switch panels, canbus electrical system with PLC based mobile controller. Allows operators to view real time engine, transmission and Rail King operating parameters as well as active and stored trouble/diagnostic codes

Other Features

Air blast horn and full light package including strobe light.



A Century of Innovation