

# TS-9972

## Reach Stacker



Rated Container Capacity 99,000-lbs. (45 t)  
First Row / 4-high Stacking 9.5-ft. (2.9 m)  
Rated Container Capacity 90,400-lbs. (41 t)  
First Row / 5-high Stacking 9.5-ft. (2.9 m)  
256-in. (6,500 mm) Wheelbase



FAITH VISION WORK



# TS-9972 Reachstacker

## An all new series of reachstacker with you in mind.

Taylor is setting a new standard in reachstacker container handling. The new TS-9972 Reachstacker is the most durable, comfortable, and user friendly truck in the industry. The TS-9972 has all the durability and dependability that you have come to expect from Taylor.

The TS-9972 is able to stack 9.5-ft (up to 99,000-lbs) 4-high in the first row. At the fifth position in the first row, capacity is 90,400-lbs. Second row capacity is 72,000-lbs up to 4-high. Third row capacity is 32,500-lbs up to 3-high. Capacities like that make this machine the best in any field.

Combined with new engineering, legendary durability, and unparalleled parts and service, the new TS-9972 Reachstacker from **Taylor Machine Works** is the #1 choice.



Electronic boom angle sensor mounted directly to the tower and boom gives a more reliable and precise angle reading.



For the safety of on-the-ground workers, the TS-9972 has added rear facing camera, taillights, work lights, and motion alarm to the sloping counterweight.

The Taylor designed and built steer axle is developed for the toughest working conditions. The proven design of this heavy-duty steer axle features common spindles and other components.

The TS-9972 is equipped with a 24 volt electrical system.

Maintenance was key in the development of everything on the TS-9972, such as, easy access to check points throughout the machine.

As always it's...



- Maintenance is vital to any machine's life. This is why the TS-9972 is designed to make it as easy as possible to perform the daily checks from the ground.
- With the TIER certified Cummins® engine powering the electronic, four-speed, automatic powershift control transmission, operation is smooth, precise, and reliable.
- Simple access to the internal components via the removable panels along the track area beneath the cab allows your service personnel to get the job done quicker and easier.



# Taylor TS9972 "Big Red"

Field service personnel can appreciate the easy access to internal components.

Safety is very important... Forward mounted, convex mirrors and signal lights aid in the safety of the operator and those who are nearby.

Hydraulic oil and brake oil cooler.

The high-stability, wide stance, planetary drive axle has the strength and durability far beyond what the competitors offer.

# TS-9972 Comfort, Safety &

## A comfortable and safe operator station...

...is vital to productivity. At Taylor, we understand that there is a wide range of working environments and the extremes an operator has to endure can affect their productivity. With this in mind, we set out to develop an operator area specifically for the safety, comfort, and convenience of the operator. All steel construction, ergonomic controls, a large comfortable seat, dependable climate controls, and a large open viewing area are just a few of the results.

## Simple is better...

Ergonomically designed advantages provide a more comfortable, stress free environment, allowing the operator to concentrate on productivity. Oversized windows and a T-shaped dashboard, provide excellent visibility for the operator. A low-effort joystick, which is mounted on a large and easily adjustable armrest, provides easy control of lift/lower, boom-in/boom-out, attachment rotation, side shift, and twistlock operation functions... This allows the operator to be much more efficient and productive.



## Maintenance is never an after thought to us...

Maintenance is inevitable ...so the cab can be hydraulically moved - forward or backward - for easy access to engine, transmission, radiator, pumps, etc... allowing for quicker daily checks. This results in cost saving by having minimal downtime.



# Productivity



A simple joystick is far easier to operate than multiple levers.



In cab and on boom viewing of indicator lights .

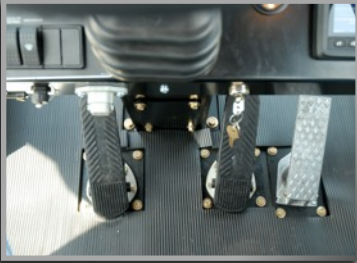

T-dash and ergonomic pedals for visibility and comfort.



Simple rear escape in case of an emergency.



Hydraulically moving cab gives access to service areas.



# TS-9972

# Reach

Features an over sized rotate bearing and gearing for extended service life. Attachment will rotate 95° CCW and 185° CW.

The structure is a simple, rugged, box frame design with two common expansion frames and one center box frame. The spreader has an open design for easy inspection and maintenance and has oversized wear pads for extended service life.

The attachment has standard ISO twistlocks for 20-ft. (6.1 m) and 40-ft. (12.2 m) positions.

All spreader cylinders are mounted on the outside for easy access. The spreader width is achieved by hydraulic cylinders, no chains or motors.

Vertical lift feature makes the operator more productive by adjusting the boom extension to meet the lift needs.

Multiple work lights.

In cab twistlock signal lights are amber, green and red. Cab windows are large for superior visibility.

Hydraulically powered cab movement is standard for easy access to engine, radiator, transmission, pumps and other components.

The 2-stage heavy-duty, dry type air cleaner has a built-in pre-cleaner, safety element, and a restriction warning light.

High stability, wide stance drive axel.

A fuel cooler is standard to increase fuel efficiency.

## Rated Capacities:

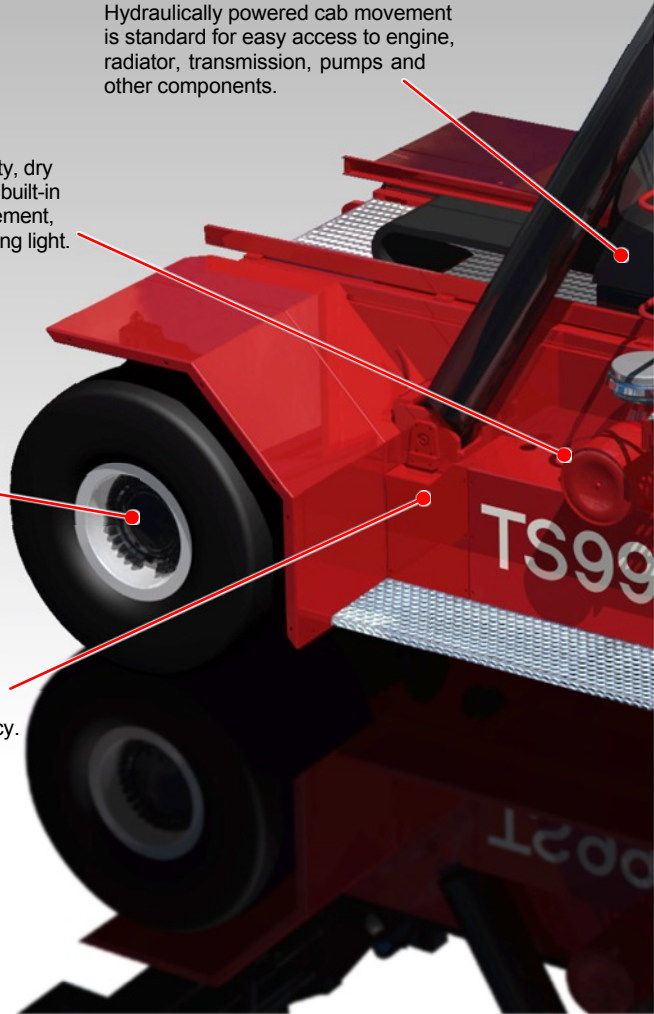
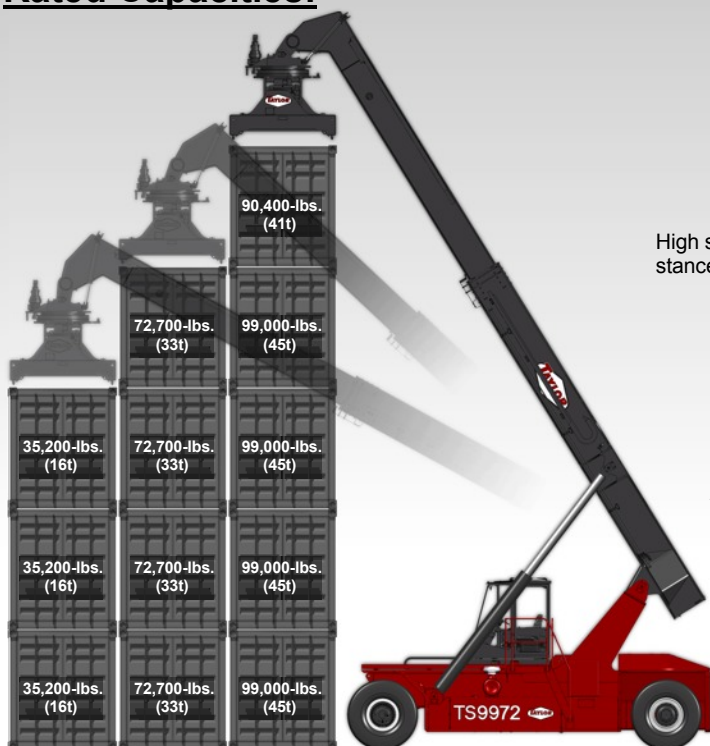

# Stacker



FAITH VISION WORK

Fatigue resistant structure designed specifically for heavy reach stacker duty cycles. The boom has full penetration welds for increased resistance to fatigue and oversized wear pads for extended service life.

The standard, air conditioned, shock mounted cab has electric front, rear, and top wipers, and a heater/defroster with front and side window defrosting. The adjustable, air suspension seat has flip-down, adjustable angle arm rests and an operator seat belt.

Standard LMI uses accurate laser technology to read the outer boom position, no string to be damaged. The laser has no wear parts.

The coolant level to be checked easily and provides optimum engine cooling.

Boom angle sensor.

The three section, vertical, bolted radiator has a separate cooler for engine coolant, separate cooler for charge air, and transmission oil. A separate cooler cools the hydraulic oil. The cooling system has a completely unrestricted air flow.

The all-welded frame has a bolt-on, contoured, counterweight. The chassis can be disassembled down to 96" width for shipping.

The steer axle has a single-cylinder design with tapered wheel bearings. The spindles are fully sealed and never needs adjusting. The over sized kingpin has self lubricating thrust washer and aluminum/bronze sleeve bushings for extended service life.

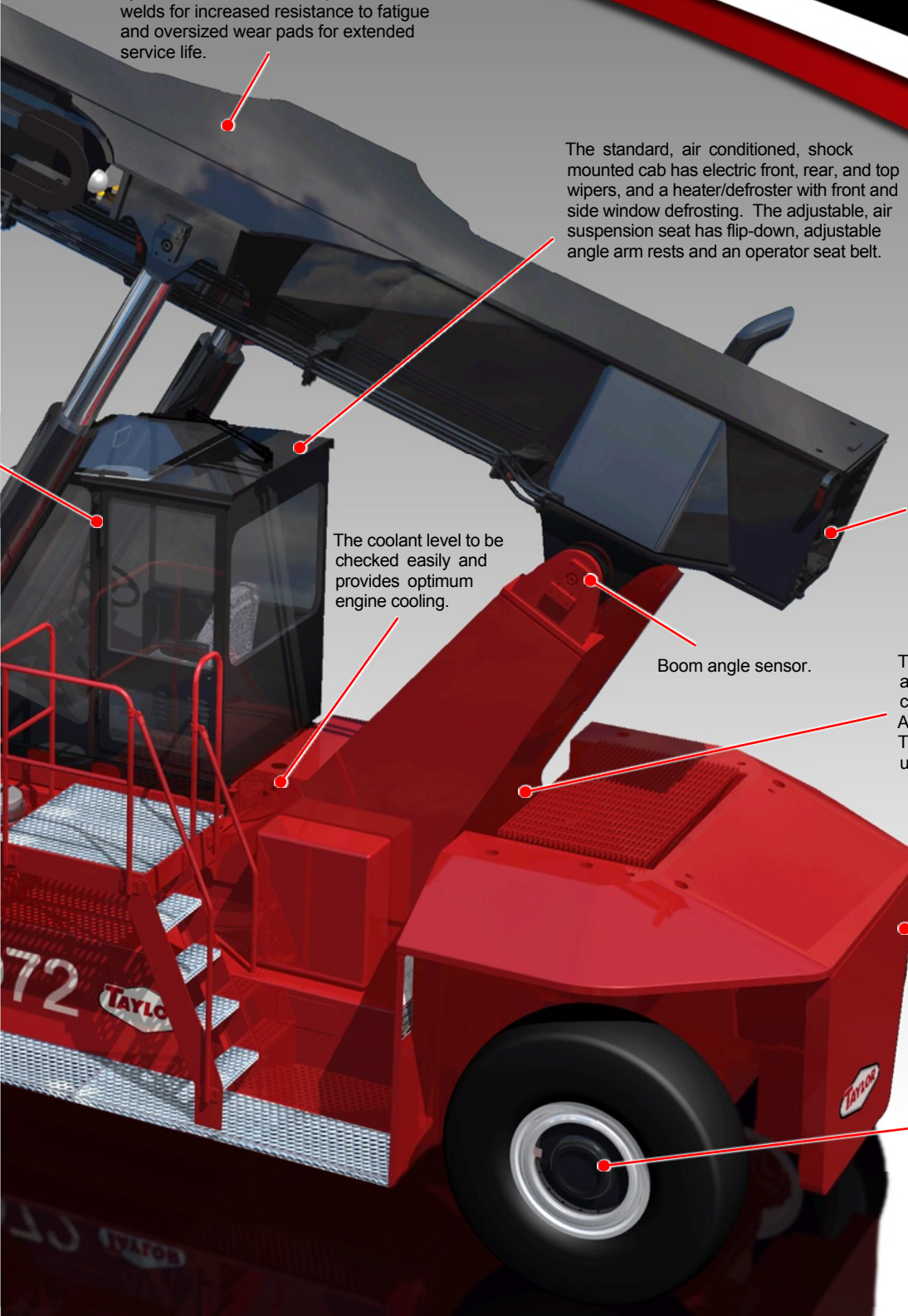

# TS-9972 Boom & Attachment

## Extra Long Life...

The competition tries to meet the industry standards. At Taylor, we go far beyond the standard. The TS-9972 is designed to be superior in every way. Instead of the typical 600,000 cycle life, we offer you a 1,000,000 cycle life in our new spreader. Longer life means more cost savings to you with far less downtime. We even simplified the system to make it easier to operate, service, and maintain.



## Open Design...

The advantage of this open design is easy access to hydraulic cylinders, valves, hoses, electrical components, etc... allowing for quicker preventative maintenance and service diagnostics. Components are not hidden inside the attachment structure. No need to disassemble the attachment to service or replace a damaged part anymore.

## More Benefits...

Oversized wear pads, rotate bearings and gearings, as well as full penetration welds, ensure extended service life. A load moment indicator, in conjunction with accurate laser technology to read the boom's precise position, replaces mechanical systems and is standard on the TS-9972.

The vertical lift feature takes the operator effort out of lifting a load and extending the boom. A simple one step operation takes care of that for the operator allowing the operator to be more productive.





Hydraulic allow 95° of CCW rotation and 185° of CW rotation for superior maneuverability.



Fatigue resistant, telescopic boom gives superior life.



Hydraulic sideshift and mechanical pile slope. (Hydraulically powered pile slope and wide twistlock position available.)

Designed for **1,000,000 +** Cycle Life!!!

*That means more productivity for your investment!*



**TAYLOR** Designed  
**TAYLOR** Built  
**TAYLOR** Tested

# TS-9972 Chassis & DriveTrain



The proven Taylor designed steer axle has a single cylinder, common spindles, fully sealed wheel bearings that never need adjusting and heavy-duty links.

## Precise Control...

The drivetrain works flawlessly to provide power and control through all RPM's whether you're lifting, riding or hauling a load... you are in control.

The operator has the ability to inch the truck along at an even speed, even if carrying a full load at full power.

A proven drive and steer axle design gives an operator the maneuvering capability they need to transport a load safely and efficiently.

## Strength, Power, and Precision...

**This is not just another reachstacker.** The new TS-9972 is unlike anything in the market.

We have engineered this line of machines to be as reliable and durable as possible. Long life, serviceability, comfort, power, and performance were the driving force in the engineering and design of this new line of reachstackers.

The smooth and dependable action of the 335-hp, TIER certified Cummins® diesel engine with its four-speed electronic automatic powershift control transmission, wide-stance planetary drive axle, and proven single cylinder design steer axle set inside the rugged, heavy-duty chassis lets you know in a moment that you are driving something different.

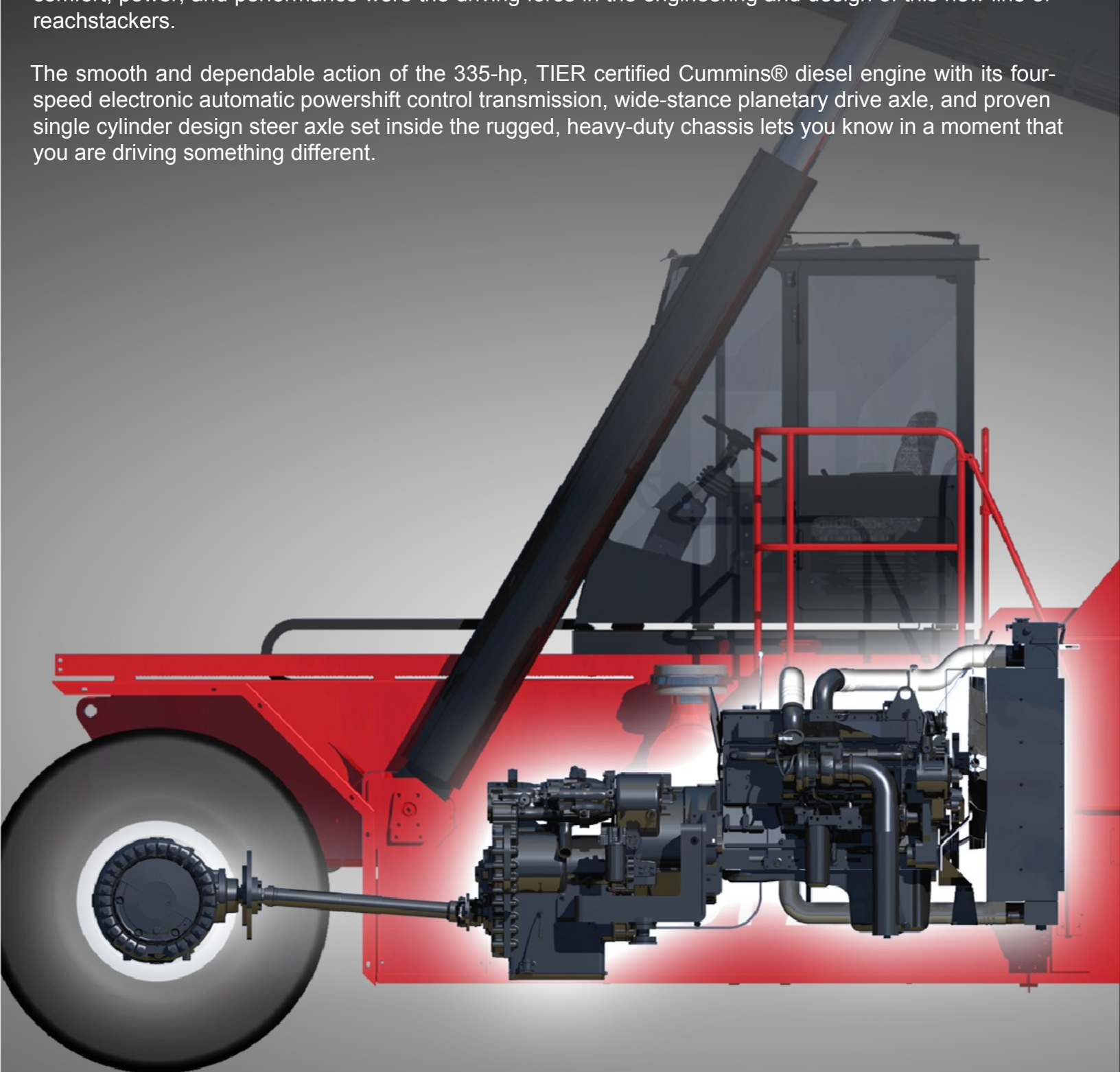

# The Best Support In The World!



No-one can match our record for service and reliability.

Worldwide customer service, backed by over 82 years of Taylor® customer satisfaction and trust.



**Sudden Service, Inc.**  
649 N. Church Ave.  
Louisville, MS 39339-2022  
Phone (662) 773-8056  
Fax (662) 773-9157  
[suddenserviceinc.com](http://suddenserviceinc.com)

**you can depend on**

“*Big Red*”

is a personal and collective commitment from the Taylor "Big Red" Team® to every customer. Customer needs and expectations are the main priorities for Taylor® engineering, manufacturing, marketing, and service organizations. Sudden Service, Inc.® and our worldwide Taylor® dealer network are ready to respond to your requests for support twenty-four hours a day, seven days a week!

**Genuine Parts • Unbeatable Service • Trusted Support**



**Taylor Machine Works, Inc.**  
650 North Church Avenue  
Louisville, Mississippi 39339-2017  
Phone (662) 773-3421 Fax (662) 773-9146  
[taylorbigred.com](http://taylorbigred.com)

TMW-BR-3002 10/6/11