

PARTS LIST			
ITEM	PART NO.	QTY	DESCRIPTION
1	T-010-7129	2	TRUCK ASSY, MOTION CONTROL
2	M-098-7111	1	BODY ASSY
3	M-024-2613	1	STENCIL ARRANGEMENT JOB 2989
4	D-066-7009	1	AIR DRIVE ARRANGEMENT REXROTH
5	D-020-7006	1	DOOR OPERATING MECHANISM ARRGT FIBERGLASS CYLINDER
6	B-003-7103	1	BRAKE ARRANGEMENT RD-VI CAR
7	U-048-7102	1	UNDERFRAME ARRGT

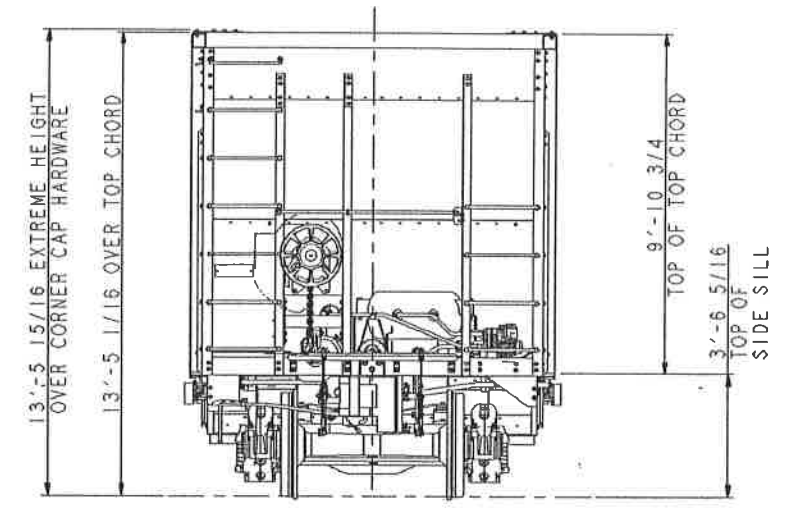
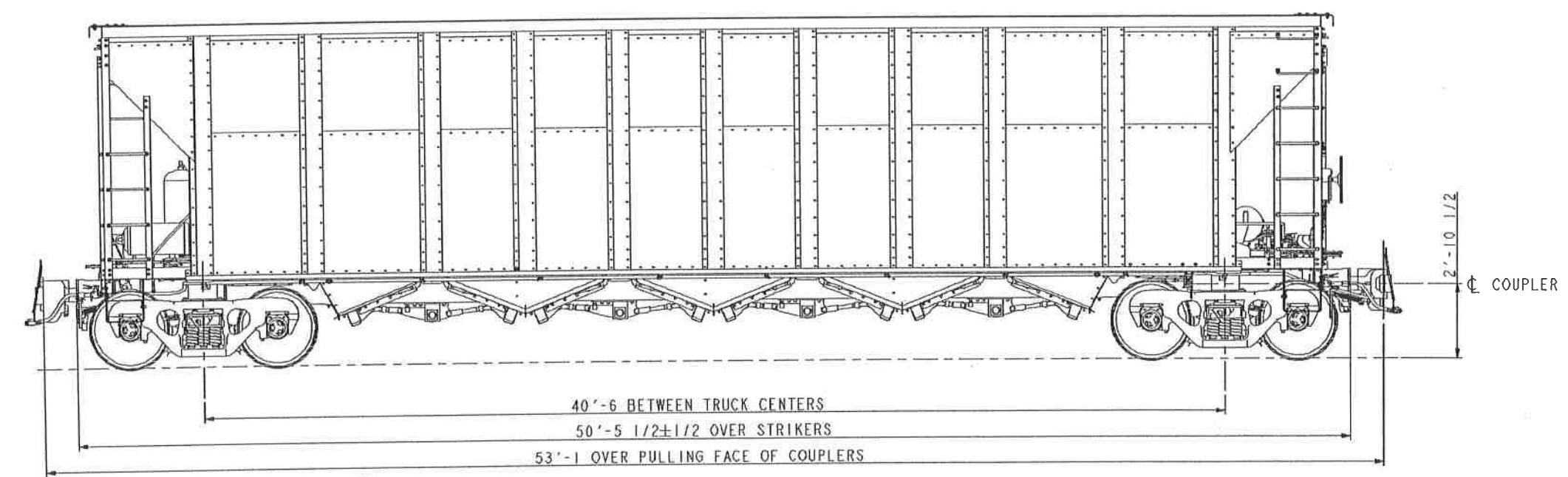
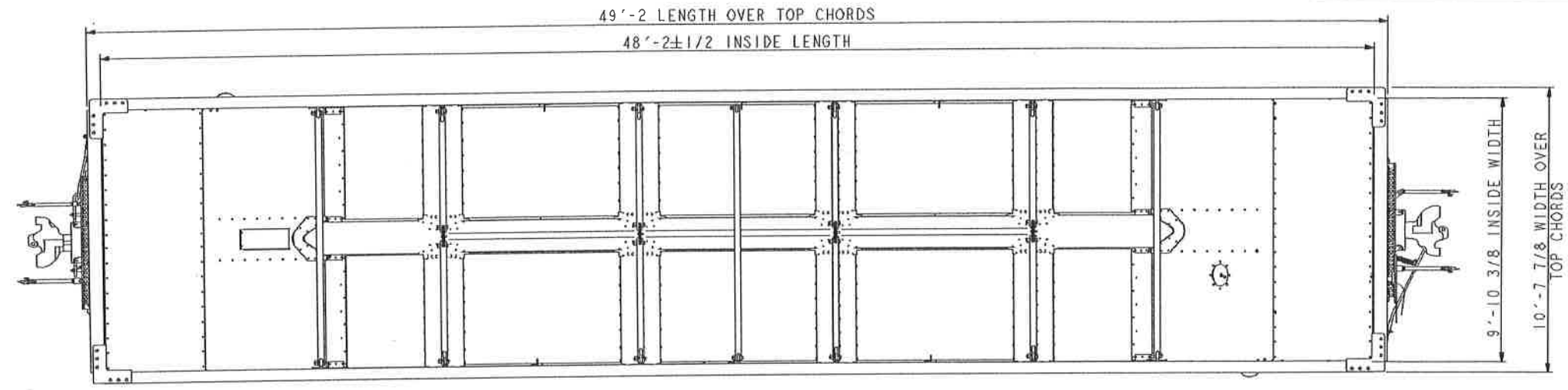

CUBIC CAPACITY
 LEVEL FULL ----- 4,207 CU. FT.
 WITH 10" HEAP ----- 4,603 CU. FT.

REV	BY	DATE	REVISION
TOLERANCES UNLESS OTHERWISE SPECIFIED ON THIS DRAWING THE FOLLOWING TOLERANCES SHALL APPLY: SEE D-145000 FOR ADDITIONAL TANK CAR TOLERANCES. FRACTIONS: MACHINED $\pm 1/64$ (.016) ALL OTHERS: UNDER 2" $\pm 1/16$ "; 2"-10" $\pm 1/8$ "; 10"-20" $\pm 1/4$ "; OVER 20" $\pm 1/2$ " DECIMALS: 3 PLACES $\pm .005$ "; 2 PLACES $\pm .03$ "; 1 PLACE $\pm .1$ " ANGLES: MACHINED $\pm 1/2$ DEG; ALL OTHERS ± 1 DEG			
THIS DRAWING CONTAINS CONFIDENTIAL AND PROPRIETARY INFORMATION OF TRINITY RAIL GROUP, LLC. THE DRAWING IS PROPERTY OF TRINITY RAIL GROUP, LLC AND IS LOANED FOR ENGINEERING REVIEW ONLY. THE DRAWING MAY NOT BE COPIED OR USED FOR ANY OTHER PURPOSE WITHOUT THE WRITTEN CONSENT OF TRINITY RAIL GROUP, LLC AND SHALL BE RETURNED ALONG WITH ALL COPIES UPON DEMAND. © TRINITY RAIL GROUP, LLC 2004			
			GENERAL ARRANGEMENT RD VI COAL CAR JOB 2989
DRAWN: DDG 11-3-04			
CHECKED: PJR 11-3-04			
APPROVED: CCH 11-3-04			
1st FILE: 2989			SHEET 1 OF 1 REV -
NLA: -			
WEIGHT: -			
M-042-7124			DRAWING NO: M-042-7141